

Submittal Data Sheet

Project Name:		Approval:	
Location:		Date:	
Engineer:		Construction:	
Submitted to:		Unit #:	
Submitted by:		Drawing #:	
Reference:			

Model	
Indoor unit model	DHP14-18-12-U
Outdoor unit model	OHP14-18-12-25



PERFORMANCE DATA

Power supply	Ph-V-Hz	208-230V,1Ph,60Hz
Cooling		
Capacity	Btu/h	16500
Input	W	1320
Rated current	A	6.0

Heating at 47

Capacity	Btu/h	19000
Input	W	1900
Rated current	A	8.7
COP	W/W	2.93

Electrical

MINIMUM CIRCUIT AMPACITY	A	18
MAX. FUSE	A	25
Connection wiring		14*4 AWG

Compressor

Model		ATF235D22UMT
Type		ROTARY
Brand		GMCC
Capacity	Btu/h	24345
Input	W	1970
Rated current(RLA)	A	12.9
Locked rotor Amp(LRA)	A	---
Thermal protector		---
Thermal protector position		---
Refrigerant oil/oil charge	ml	POE(VG74)/670

SYSTEM DATA

Design pressure	PSIG	550/340 PSIG
Refrigerant type	oz	R410A/68.8
Refrigerant precharge	ft	25
Additional charge per ft.	oz	0.16
Liquid side/ Gas side	mm(in)	Φ6.35/Φ12.7(1/4"/1/2")
Max. refrigerant pipe length	ft	98
Max. difference in level	ft.	66

ESP

ESP range	In. wg.	0-0.40
-----------	---------	--------

INDOOR UNIT DATA

Indoor fan motor		
Model		ZKFN-160-8-1-2
Type		DC
Input		90.0
RLA	A	1.2
LRA	A	---
Winding Resistance	Ω	---
Capacitor	uF	---
Speed(Hi/Mi/Lo)	r/min	850/700/450
Air flow & Noise level		
Indoor air flow (Hi/Lo)	CFM	530/450/371
Indoor noise level (Hi/Lo)	dB(A)	39/37/35

Indoor unit

Dimension(W*D*H)	inch	34.65x28.53x8.27
Packing (W*D*H)	inch	42.13x28.53x10.63
Net/Gross weight	lbs.	54/66

OUTDOOR UNIT DATA

Outdoor fan motor		
Model		ZKFN-50-8-2
Type		DC
Input		115
RLA	A	0.42
LRA	A	---
Winding Resistance	Ω	---
Capacitor	uF	---
Speed	r/min	850
Air flow & Noise level		
Outdoor air flow	CFM	1355
Outdoor noise level	dB(A)	59

Outdoor unit

Dimension(W*D*H)	inch	33.27x14.29x27.64
Packing (W*D*H)	inch	37.99x15.55x30.11
Net/Gross weight	lbs.	107.4/115.1

Operation temperature

Indoor(cooling/ heating)	Deg. F	62~90/32~86
Outdoor(cooling/heating)	Deg. F	-22~-122/ -22~86
Application area	sq.ft	258-376

INDOOR UNIT

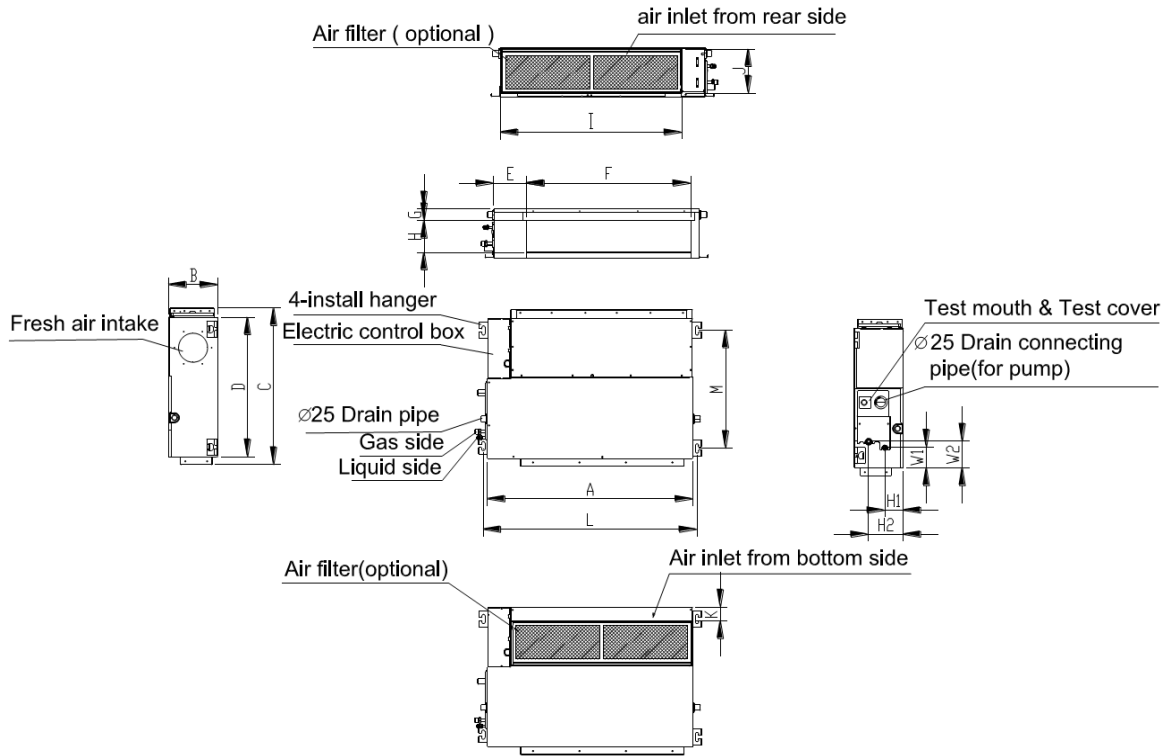

Capacity (Btu)	Outline dimension(mm)				Air outlet opening size				Air return opening size			Size of mounted plug		Size of gas and liquid valve			
	A	B	C	D	E	F	G	H	I	J	K	L	M	H1	H2	W1	W2
18000	880	210	674	600	140	706	50	136	782	190	40	920	508	78	148	88	112

OUTDOOR UNIT

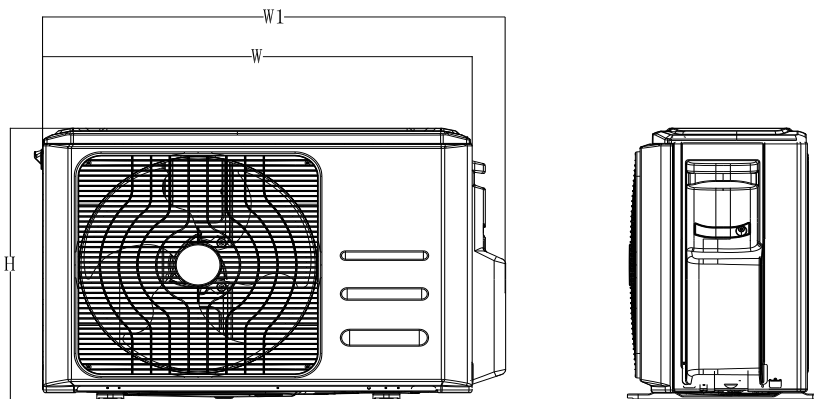

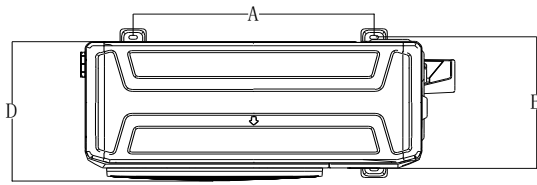

Model	W (inch)	D (inch)	H (inch)	W1 (inch)	A (inch)	B (inch)
OHP14-18-12-25	33.3	14.3	27.6	36.0	21.3	13.8

MTIU-18HWFN1-M

